

Single Stage Integrally Geared Turbocompressor

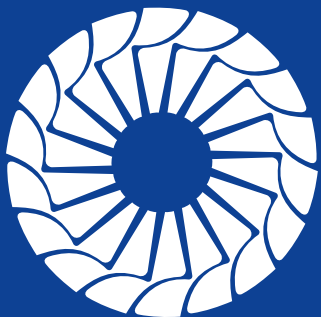

NexTurbo

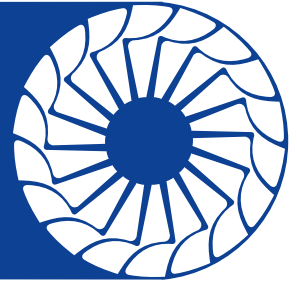

A passionate and experienced team

Next Turbo was founded with the belief that robust integrally geared turbocompressors are a superior solution for the municipal and industrial waste water industries - today and for years to come.

The management team combines nearly one hundred years of experience within the industry and is passionate about turbocompressors. Next Turbo builds to order, relying on state-of-the-art materials and design techniques to create the most intelligent turbo for your market. Our mission is to provide the industry with a modern, heavily-duty and reliable compressor solution for our customers.

Manufacturing and assembly factories are located in Varese, Italy, close to Milano and the Swiss border, and Kansas City, Missouri, central to North America.

We welcome you to factory-witness our capabilities and compressor performance test.



Our Technology



GTB - T20 X B5 with
Compact Enclosure

Proven, Compact, Efficient & Affordable

Are geared turbocompressors too expensive?

Not any more. The low air flow range of the wastewater treatment aeration industry has traditionally been dominated by inefficient, volumetric blowers. Today, with more focus on energy efficiency and cost competitive centrifugal technologies, the paradigm has shifted. Next Turbo offers you an reliable, affordable solution.

Is a packaged solution possible?

The plug & play package concept makes for easy installation and quiet performance. This compact arrangement is available to Next Turbo's integrally geared turbocompressor line.

Why accept limitations?

Volumetric machines face poor operating efficiencies, while direct driven, speed-controlled turbo blowers have a limited turndown, reduced lifetimes, and are more sensitive to ambient conditions and air particulates. The Next Turbo integrally geared single stage turbo-compressor line combines all the advantages of well established geared turbocompressors and the latest engineering advancements in rotating equipment and fluid dynamics.

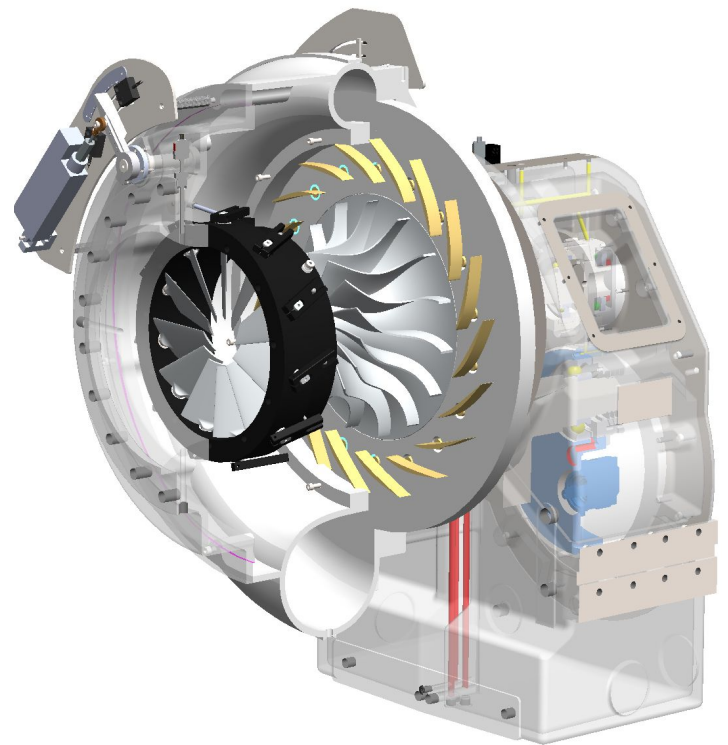

Next Turbo offers the advantages of recent technologies without their operational limitations or fragile design. We offer an affordable, robust machine with the highest efficiency and maximum turndown capability.

Product Portfolio



GTB - T40XY

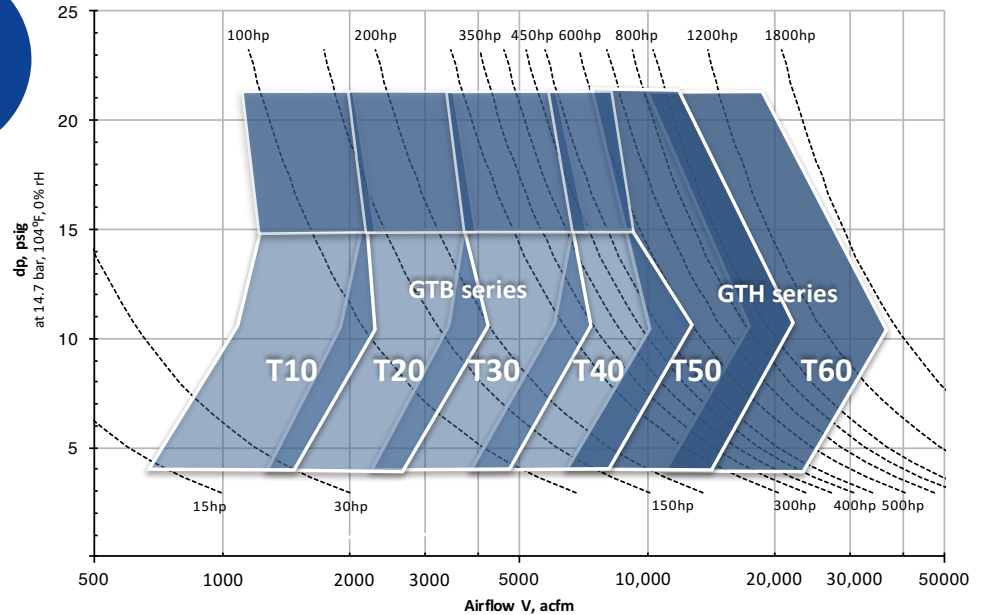

Our product portfolio

Our integrally geared centrifugal turbocompressor range features six distinct frame families up to 1750 HP installed motor power, customizable to your project needs.

The T10 through T30 frames are available in a plug & play compact package with all auxiliary parts fully enclosed and ready to start, or with a more traditional assembled modular enclosure. The motor configuration can be chosen as either low voltage D-flange, as well as medium voltage foot-mounted.

All Next Turbo turbocompressor models feature discharge diffuser vanes to achieve exceptional turndown range and one-point or two-point regulation control.

Flexible and stable blower operation with actual airflow range between 40-100%

Highest efficiency over entire turndown range with our diffuser vane regulation

Power optimization with our two-point control philosophy

Longest lifetime - offers more than 20 years of lifetime for your investment

Reliable operation - thanks to a robust mechanical design—perfect for challenging environments

Proven technology - with a global reference base in waste water aeration applications

Spare parts security- with industry-standard components readily available in the market

Product nomenclature definition

Example

GTB-T20XY

GT	Geared Turbocompressor
B	Ceramic ball bearings 'B' or Hydrodynamic bearings 'H'
T20	Frame size Turbo T10,T20,T30,T40,T50,T60
XY	Compressor regulation control: X, XY, XZ (see descriptions on next page)

Wide regulating range

At the heart of each turbocompressor package is the compressor core unit and its most important characteristic: the flow & pressure regulating system. The choice of regulating system determines the turbocompressor's performance over the entire operating range, especially at off-design conditions. It also determines the level of turndown possible. All Next Turbo turbocompressors typically feature a wide 40-100% airflow regulation range.

Turbocompressor Regulation Control

Compressor envelope and curves
from top to bottom: Regulation type 'X',
Regulation type 'XY', Regulation type 'XZ'

Regulation type 'X' Mechanical 1-point control

Flow and pressure regulation using discharge diffuser vanes for wide turndown capabilities. By adjusting the discharge diffuser vanes the compressor operating envelope is extended along the flow-axis.

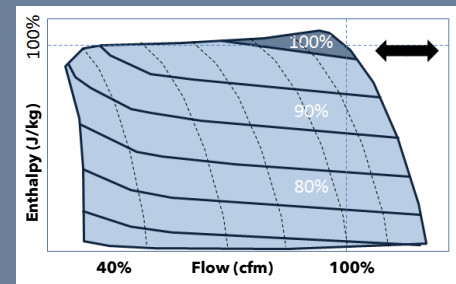

Regulation type 'XY' Mechanical 2-point control

Flow and pressure regulation using the discharge diffuser- and inlet guide vane systems for optimal efficiency. The wide turndown of an X-type machine is combined with mechanical power optimization to compensate for air temperature, humidity, and pressure fluctuations.

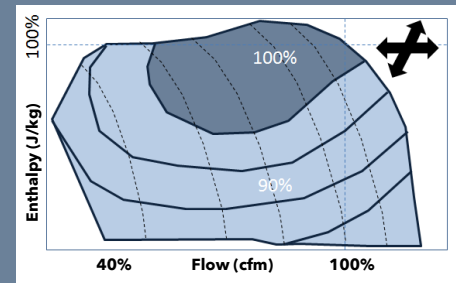

Regulation type 'XZ' Electrical/mechanical 2-point control

Flow and pressure regulation using both discharge diffuser vanes and a variable frequency drive for increased flexibility. The operating envelope of our X-type control is extended along the pressure-axis. This control philosophy is suited for varying liquid level applications.

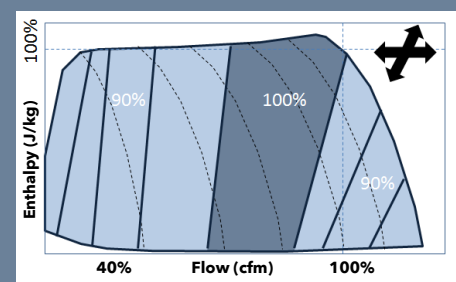

Speed-only control using a VFD is common among other single-stage turbocompressors, but involves compromises

Most turbocompressors on the market, especially directly driven units, only apply simple speed control to regulate airflow. An adjustment in speed reduces the flow linearly, however, the differential pressure is reduced by a power of two. This choice of regulation forces a trade-off between airflow range and efficiency. In order to allow a reasonable airflow turndown for simple speed control, the compressor needs to be over-designed for pressure in order to meet the system back-pressure requirement over the entire airflow range.

Compressor Components

GTB - T20X with
Compact Enclosure
and Soft Starter

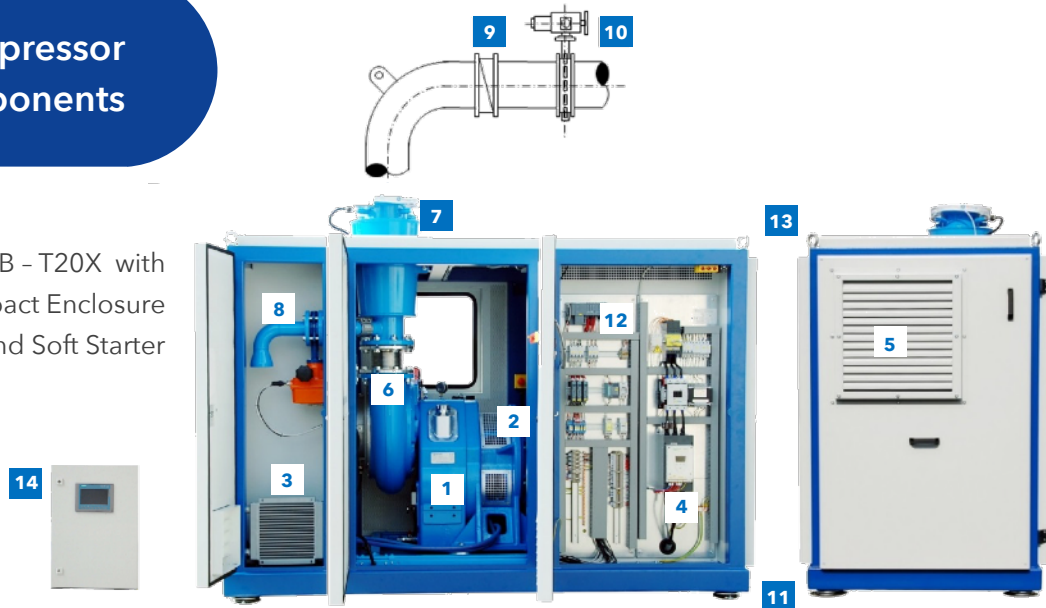

1. **Turbocompressor** - Integrally geared turbocompressor with integrated gearbox and lubrication system, utilizing 1-point or 2-point regulation control system for wide turndown and highest efficiency.
2. **Electrical drive motor** - Available in standard D-Flange low voltage configuration for 60Hz. Utilizing medium voltage motors is also possible. Motors selected from first class manufacturers, IEC3 and NEMA premium efficiency standard.
3. **Air/Oil heat exchanger** - Complete independent and integrated air to oil cooling loop system.
4. **Motor control center** - Full motor control center, either as DOL, Soft Starter or Variable Frequency Drive with all auxiliaries and optional electrical filters.
5. **Inlet silencer/filter** - Inlet silencer as a labyrinth-type with coarse inlet pre-filter and fine pocket filter with 95% filtration.
6. **Flexible compensator** - Flexible discharge compensator with stainless steel ASTM flexible element and turn-able aluminum flanges.
7. **Discharge cone diffuser**- Conical diffuser cone with integrated outlet silencer for recovery of up to 90% of the dynamic pressure.
8. **Blow-off valve/ silencer** - Butterfly valve for mounting between flanges according to ASTM, and equipped with an electric actuator as well as a hand wheel for manual operation, includes limit switches.
9. **Check valve** - Non-return check valve, with dual spring loaded flaps.
10. **Isolation valve (electric)** - Butterfly valve for mounting between flanges according to ASTM, and equipped with an electric actuator as well as a hand wheel for manual operation, includes limit switches.
11. **Vibration dampers/ mounts** - The vibration dampers are mounted between the compressor base and the compact enclosure floor.
12. **Local control panel (LCP)** - Equipped with PLC and HMI touch screen. Features all functions for start/stop of the compressor, air flow regulation, as well as the security system.
13. **Acoustic enclosure**- Silencer hood integrated with all accessories, factory mounted and tested. All side and top panels are either hinged as a door, or quickly and easily removable for comfortable access to the internal components. Each side is equipped with an inspection window. The hood is equipped with an internal light, and a heat extraction fan, all operated from the local control panel.
14. **Master control system (MCS)** - Master control system to automatically regulate the air flow of each compressor via cascade control. The MCS is equipped with a PLC and a HMI.



Next Turbo uses industry-standard components which can be regionally sourced or serviced

Acoustical Enclosure Options

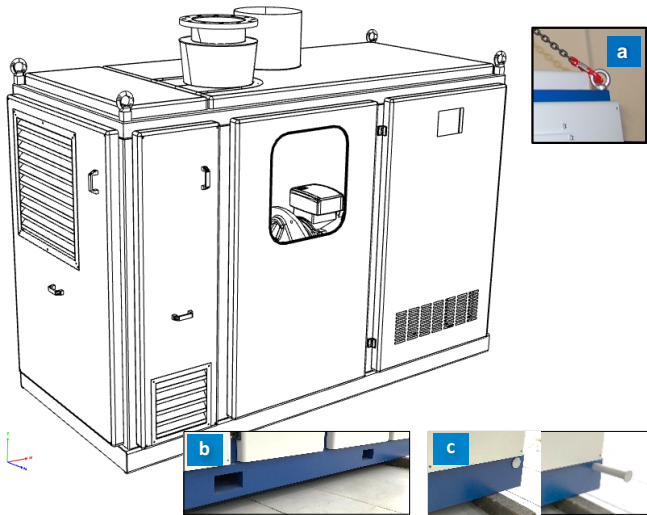

Compact enclosure for compressor with D-flanged console, available up to 400 HP motor size. All components fully enclosed, including optional Motor Control Center. The compact enclosure can be lifted via eyebolts (a), forklift (b) or special bolts (c).

Compact plug & play package

A fully enclosed, pre-wired and tested plug & play solution

The compact acoustic enclosure integrates all required accessories, factory mounted and tested. Main steel structure comes with all side and top panels either hinged as a door, or is quickly and easily removable for comfortable access to the internal components. Each side is equipped with an inspection window. The compact enclosure comes with an internal light and heat extraction fan, controlled from the local control panel. The peak noise during start and stop is eliminated due to the integrated blow-off valve and silencer. The package is easy to handle due to access holes for fork-lift at the base plate and dedicated lifting lugs on top of the enclosure.

Dedicated compartments can be provided for local control panel, MCC configuration with VFD, soft starter, DOL and the inlet system. Only one external connection at power supply is necessary, accessible from top or bottom. The Next step is to press the start button.

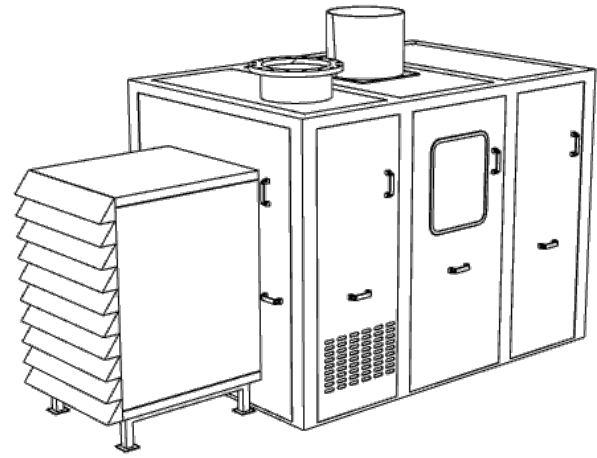

Modular enclosure for compressors both with D-flanged console or foot-mounted basement, delivered as a build up kit, covers the full range up to 1750 HP motor size. The local control panel and the optional Motor Control Center are built as stand alone panels. The blow-off valve, check valve and inlet system are external and shipped loose.

Modular package

A traditional modular enclosure for easy installation customized to site conditions

The modular enclosure is built around the compressor unit, which is installed on the floor. The modular enclosure consists of several doors (modules) which are easily removed in case of maintenance (lift and remove). Some doors are hinged and equipped with a window. Both structure and sound absorbing panels are made of sandwich bended Aluzinc steel sheets filled with mineral wool and a plaster sheet.

The inlet silencer is installed in front of the unit and connected to the compressor inlet via a flexible metal joint. A stand alone local control can is shipped loose and mounted outside of the enclosure.

Both Compact and Modular solutions are suitable for outdoor installation

Customization Options

Available discharge orientations within a compact enclosure as integrated packaged solution.

A modular enclosure or no enclosure can accommodate discharge orientations every 15°.

Compressor discharge configurations:

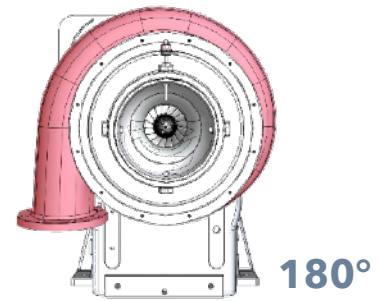
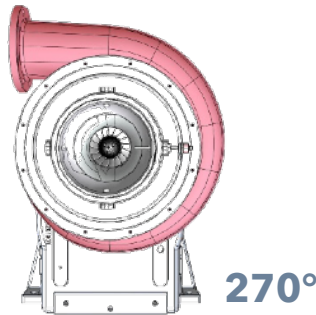
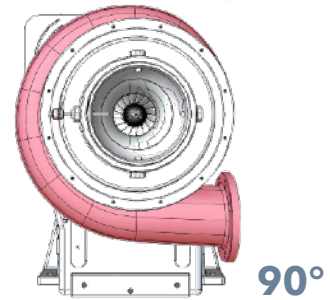
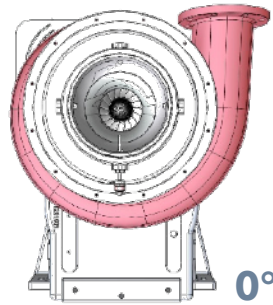

Upgrade options

Safety instrumentation options extend the instrumentation of the machine with the below options:

- Compressor bearing temperature monitoring
- Vibration monitoring
- Extended motor winding temperature monitoring
- Motor bearing temperature monitoring
- Reverse rotation monitoring

Motor space heater for cold and humid environments.

Other PLC or network platforms - Choose between Siemens S7, Allen Bradley and Schneider. Profibus, Ethernet or Modbus.

Remote monitoring & service integrates our intensive care and fast troubleshooting options.

Commissioning and training of staff on site - factory support on site for a successful start-up.

Service packages and kits- Wear and tear as well as recommended spare parts.

Medium voltage drive motor- Reduce investments in your electrical plant setup by utilizing medium voltage drive motors.

Water cooling - Air-to-oil heat exchanger with a water cooling option for hot climates.

Extended inspection and test plan - Add additional ITP items, such as:

- Overspeed test of impeller
- Dye penetrant test of impeller
- Hydrostatic test of volute

Performance or performance verification test - Performance test according to ASME PTC and verification of guaranteed power figures.

Vibration- sound measurements and mechanical run test are standard scope items for each delivery.

Material description

Main Castings	Nodular cast iron EN GJS-400/15 EN1563, design: 6,5 bar, 200°C
Impeller	Aluminum W.Nr.3.1924 AlCu2MgNi; milled from a solid forged block; open, with radial backward-leaning blades, can withstand corrosion up to 10ppm of H2S
Mechanical Components	Steel
Labyrinth Seals	Aluminum alloy

Vanes	Stainless steel AISI 316
Bearings: fast shaft	High precision ceramic angular contact ball bearings or hydrodynamic oil film bearings
Bearings: slow shaft	Deep groove ball bearings
Gears	High tensile steel 16NiCrS4, hardened and ground
Lubrication	Forced oil mist lubrication with integrated positive displacement pump, oil/air cooler, oil filter 10 µm

Power connection

Low voltage - between 460 and 600Vac - 3-phase - 60Hz. Compact enclosure includes all power switches and connections. Main power connection accessible from bottom or top.

Medium voltage - between 2300Vac and 6000Vac - 3-phase - 60Hz, foot-mounted frame equipped with selectable instrumentation and flexible coupling.

Inlet filter/ silencer

Selection criteria - Inlet suction air volume, designed to reduce air-speed to 700 ft/min. The below dimensions are for the coarse pre-filter as well as for the fine pocket filter.

Max airflow	Filter size (Inches)	Weight (lb)
< 2,400 cfm	24 x 24	441
2,400 - 4,800 cfm	36 x 36	772
4,800 - 7,000 cfm	36 x 47	904
7,000 - 9,800 cfm	47 x 47	1102
9,800 - 11,200 cfm	47 x 63	1367
11,200 - 14,800 cfm	63 x 63	1565

Discharge cone diffuser

Selection criteria - The air-speed at the discharge flange of the cone, designed not to exceed 4,000 ft/min in order to minimize piping pressure losses and reduce acoustic noise in the pipe.

Model	Cone Size (NPS inches)	Weight (lb)
T-10	5 / 8	165
T-10	5 / 10	176
T-20	6 / 10	265
T-20	6 / 12	287
T-30	8 / 14	375
T-30	8 / 16	386
T-40	10 / 14	419
T-40	10 / 16	441
T-40	10 / 20	463

Local control panel

The local control panel (LCP) features the main functions for starting and stopping the compressor, as well as the health monitoring procedures. Within the compact enclosure, the LCP is fully integrated in its own compartment.

Other features:

- All compressor controls, alarms, trips and all auxiliaries
- Diffuser capacity control (airflow control)
- Connection to master control system (MCS) or plant distributed control system (DCS)
- Power supply 3 x 460Vac + N + PE

Master Control System (MCS)

The MCS (Master Control System) controls the turbocompressor air flow with a high efficiency cascade control that perfectly matches process air requirements and equalizes compressor duty hours. The MCS is a stand-alone panel situated in or near the blower room.

The Master Control System with integrated Dissolved Oxygen (DO) control

The MCS-DO system covers all the functions of the MCS system, and additionally controls the aeration valves in the treatment basin based on the DO set-point and the DO process value. The DO transmitters, as well as the aeration control valves, are connected to the MCS-DO panel (via hardwire or network). The MCS-DO CPU's software, with multiple parallel algorithms, compares the DO process value to the set-point and adjusts the aeration valves accordingly.

In the highly fluctuating aeration environment, the overall system pressure in the pipe is constantly changing. The MCS-DO automatically calculates the lowest system pressure using MOV (Most Open Valve) philosophy. This function allows the system pressure to be kept at a minimum because the aeration valves will be operated in their most efficient operational ranges, reducing overall operating costs. The "hunting" phenomena, which many plants using third-party software are subject to, is also minimized by adopting this functionality.

Available PLC platforms & networks:

Model	Network
Siemens S7-ET200SP	Ethernet, Profibus
Siemens S7-300	Profibus, Ethernet
Allan Bradley	Ethernet
Schneider Modicon M2xx	Ethernet, Modbus



Cascade control

Most turbocompressors using only speed control must operate in parallel, all simultaneously adjusted at the same speed to prevent surging. Next Turbo's cascade control modulates only one blower for more precise airflow adjustments, while the remaining blowers operate at minimum, maximum airflow or standby. Typical 40–100% turndown range allows for an overlap when operating multiple blowers, providing accurate process stability.

Typical Installations



Application: Wastewater aeration
Model: GTB-T30XY
Quantity: 3 units
Horsepower: 250 HP
Additional Equipment: One Master Control System panel, nine aeration control valves, 11 DO meters and flow transmitters



Application: Wastewater aeration
Model: GTB-T20X
Quantity: 1 unit
Horsepower: 100 HP



Application: Wastewater aeration
Model: GTB-T10X
Quantity: 3 units
Horsepower: 75 HP
Additional Equipment: One Master Control System panel



Application: Wastewater aeration
Model: GTB-T20X
Quantity: 6 units
Horsepower: 125 HP
Additional Equipment: Two Master Control System panels

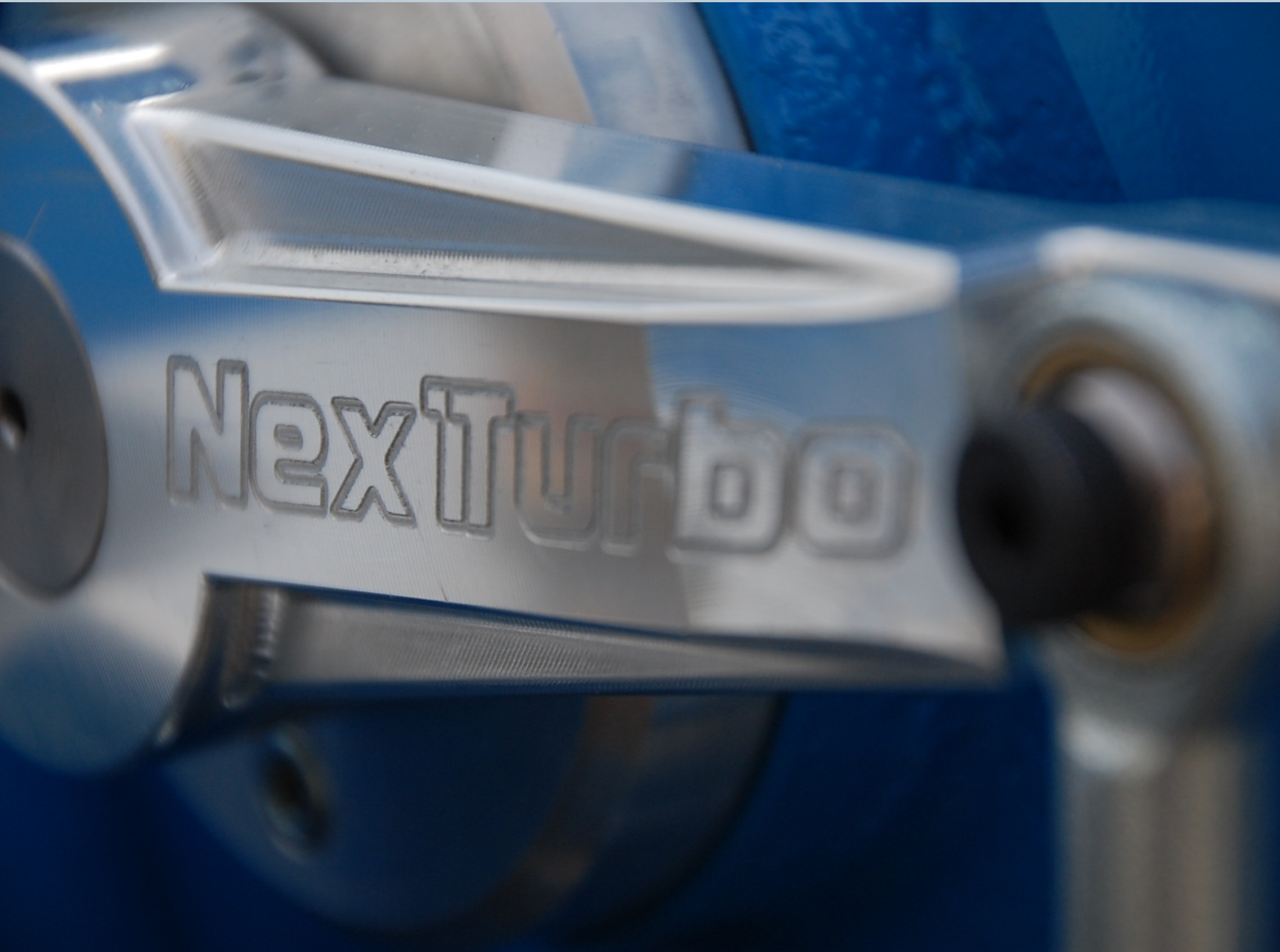

Published and copyright © 2016 – Next Turbo Americas, LLC
More information available at <http://www.next-turbo.com>

All rights reserved. Trademarks mentioned in this document are the property of NTT S.p.A., its affiliates, or their respective owners. Subject to change without prior notice. The information in this document contains general description of the technical features, which may not apply in all cases. The required technical options should therefore be specified in the contract.



<http://www.next-turbo.com>